

Harmonics compensation in a Grid-Connected Single-Phase PV Inverter

Sk.Shakeer Ahammad¹, T.Muni Prakash², P.Murali³.

Abstract- A single-phase grid-connected photovoltaic (PV) inverter topology consisting of a boost section, a low-voltage single-phase inverter with an inductive filter, and a step-up transformer interfacing the grid is considered. Ideally, this topology will not inject any lower order harmonics into the grid due to high-frequency pulse width modulation operation. However, the non ideal factors in the system such as core saturation-induced distorted magnetizing current of the transformer and the dead time of the inverter, etc., contribute to a significant amount of lower order harmonics in the grid current. A novel design of inverter current control that mitigates lower order harmonics is presented in this paper. An adaptive harmonic compensation technique and its design are proposed for the lower order harmonic compensation. In addition, a proportional-resonant-integral (PRI) controller and its design are also proposed. This controller eliminates the dc component in the control system, which introduces even harmonics in the grid current in the topology considered. The dynamics of the system due to the interaction between the PRI controller and the adaptive compensation scheme is also analyzed.

Key words: — Proportional-resonant-integral, Adaptive filters, harmonic distortion, inverters, solar energy, PRI, THD.

1. Introduction

Renewable sources of energy such as solar, wind, and geothermal have gained popularity due to the depletion of conventional energy sources. Hence, many distributed generation (DG) systems making use of the renewable energy sources are being designed and connected to a grid. The topology of the solar inverter system is simple. It consists of the following three power circuit stages:

- 1) A boost converter stage to perform maximum power point tracking (MPPT);
- 2) A low-voltage single-phase H -bridge inverter;
- 3) An inductive filter and a step-up transformer for interfacing with the grid.

The system will not have any lower order harmonics in the ideal case. However, the following factors result in lower order harmonics in the system: The distorted magnetizing current drawn by the transformer due to the nonlinearity in the B - H curve of the transformer core, the dead time introduced between switching of devices of the same leg [2]–[6], on-state voltage drops on the switches, and the distortion in the grid voltage itself.

There can be a dc injection into the transformer primary due to a number of factors. These can be the varying power reference from a fast MPPT block from which the ac current reference is generated, the offsets in the sensors, and A/D conversion

block in the digital controller. This dc injection would result in even harmonics being drawn from the grid, again contributing to a lower power quality.

The advantage of the adaptive filter-based method is the inherent frequency adaptability which would result in same amount of harmonic compensation even when there are shifts in grid frequency. The implementation of adaptive filters is simple. Thus, in this paper, an adaptive filter-based method is proposed. This method estimates a particular harmonic in the grid current using a least-mean-square (LMS) adaptive filter and generates a harmonic voltage reference using a proportional controller. This voltage reference is added with appropriate polarity to the fundamental voltage reference to attenuate that particular harmonic.

This paper includes an analysis to design the value of the gain in the proportional controller to achieve an adequate level of harmonic compensation. The effect of this scheme on overall system dynamics is also analyzed. This method is simple for implementation and hence it can be implemented in a low-end digital controller.

2. Origin of Lower Order Harmonics and Fundamental Current Control

This section discusses the origin of the lower order harmonics in the system under consideration. The sources of these harmonics are not modeled as the method proposed to attenuate those works independent of the harmonic source.

A. Origin of Lower Order Harmonics

1)*Odd Harmonics:* The dominant causes for the lower order odd harmonics are the distorted magnetizing current drawn by the transformer, the inverter dead time, and the semiconductor device voltage drops. Other factors are the distortion in the grid voltage itself and the voltage ripple in the dc bus. The magnetizing current drawn by the transformer contains lower order harmonics due to the nonlinear characteristics of the B - H curve of the core.

2)*Even Harmonics:* The topology under consideration is very sensitive to the presence of dc offset in the inverter terminal voltage. The dc offset can enter from a number of factors such as varying power reference given by a fast MPPT block.

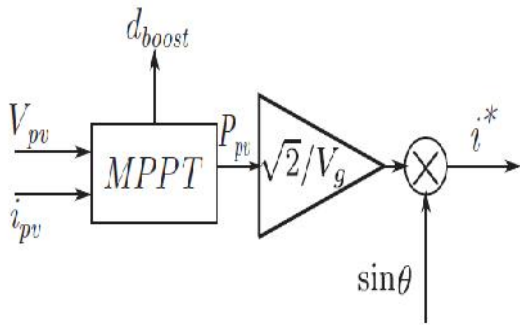

Figure 1: Generation of an inverter ac current reference from an MPPT block.

In Fig. 1, d_{boost} is the duty ratio command given to the boost converter switch, v_{pv} and i_{pv} are the panel voltage and current respectively.

B. Fundamental Current Control

1) *Introduction to the PRI Controller:* Conventional stationary reference frame control consists of a PR controller to generate the inverter voltage reference. a modification to the PR controller is proposed, by adding an integral block, G_I as indicated in Fig. 2. The modified control structure is termed as a PRI controller.

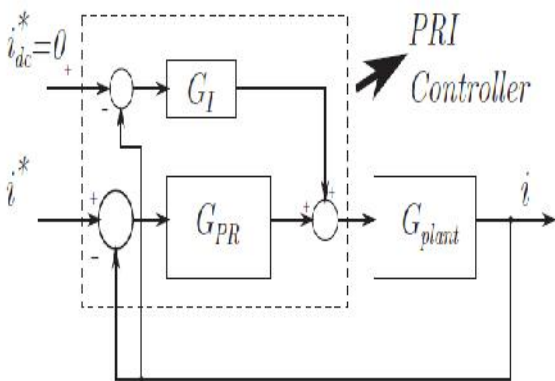

Figure 2: Block diagram of the fundamental current control with the PRI controller.

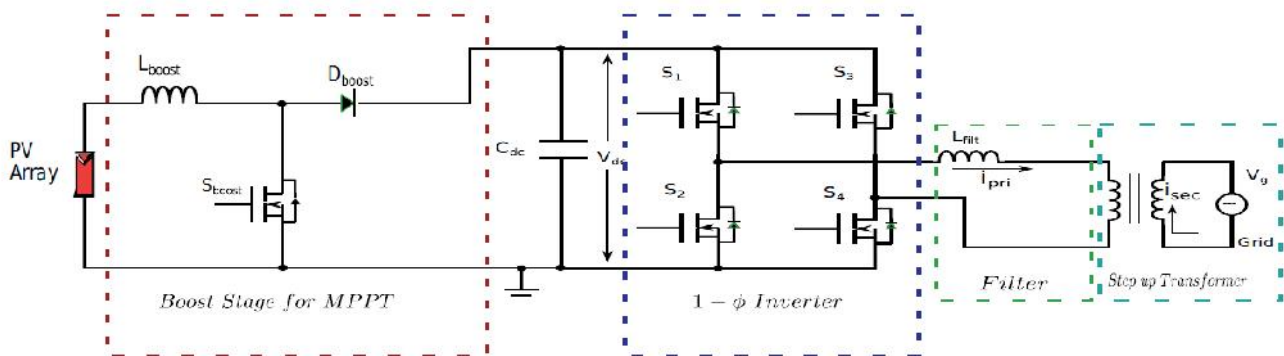

Figure 3: Power circuit topology of the 1 – phase PV system for a low-voltage inverter with 40V dc bus connected to 230V grid using a step-up transformer

3.Adaptive Harmonic Compensation

In this section, the concept of lower order harmonic compensation and the design of the adaptive harmonic compensation block using this adaptive filter are explained.

A. Review of the LMS Adaptive Filter

The adaptive harmonic compensation technique is based on the usage of an LMS adaptive filter to estimate a particular harmonic in the output current. This is then used to generate a counter voltage reference using a proportional controller to attenuate that particular harmonic.

B. Adaptive Harmonic Compensation

The LMS adaptive filter discussed previously can be used for selective harmonic compensation of any quantity, say grid current. To reduce a particular lower order harmonic (say ik) of grid current:

- 1) ik is estimated from the samples of grid current and phase locked loop (PLL) [38] unit vectors at that frequency;
- 2) A voltage reference is generated from the estimated value of ik ;
- 3) Generated voltage reference is subtracted from the main controller voltage reference.

The Fig.3 shows the power circuit topology considered. This topology has been chosen due to the following advantages: The switches are all rated for low voltage which reduces the cost and lesser component count in the system improves the overall reliability.

This topology will be a good choice for low-rated PV inverters of rating less than a kilowatt. The disadvantage would be the relatively larger size of the interface transformer compared to topologies with a high-frequency link transformer.

Grid Connected Single-Phase PV Inverter With PRI Controller

The grid connected single-phase PV inverter with PRI controller is shown in fig.4.

The Fig.4. Consists of PV array, boost converter, single-phase inverter, an inductive filter& a step-up transformer for interfacing with the grid. The PV array gives the values are $V_{PV}=29.62V$, $I_{PV}=9.903A$, $V_{DC}=43.77v$. The boost converter boost up the voltage & current. The capacitor is used to the purpose of continuous current flowing. The inverter converts DC power to AC power. In the inverter each IGBT has resistance of 0.1 . The transformer having nominal power of 150VA; operating frequency is 50HZ, $L=500e^{-3}$, $L_1 = 100e^{-6}$, $L_2=1e^{-3}$, $C=6600e^{-6}$, $C_1=200e^{-6}$, $R=200$, $R_1=0.1$. In ac voltage source, peak amplitude=230V.it is also consists of PRI controller.

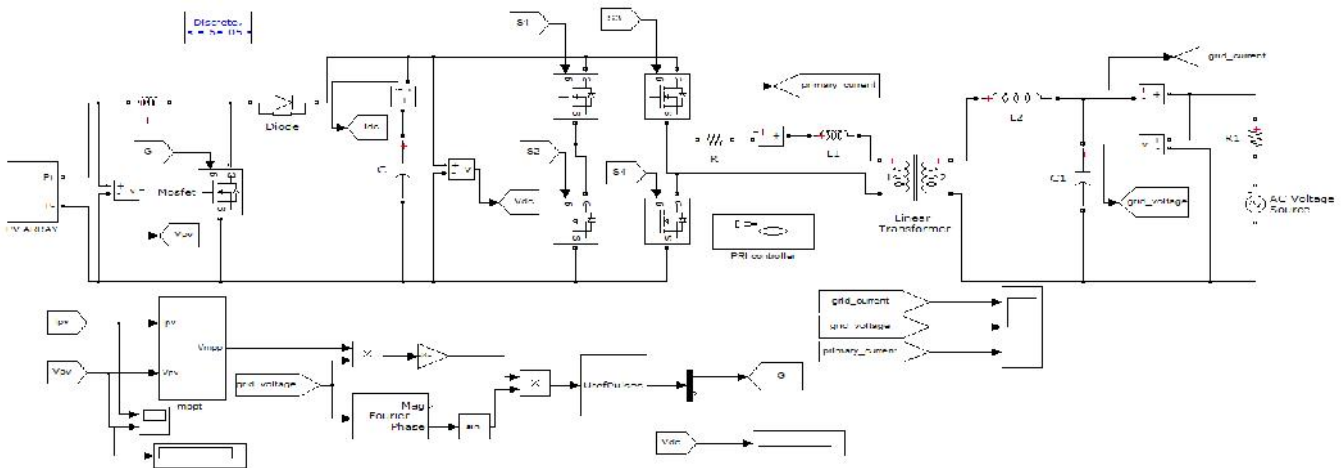

Figure 4: Grid connected single-phase PV inverter with PRI controller

The block diagram of PRI controller is shown in fig.5.

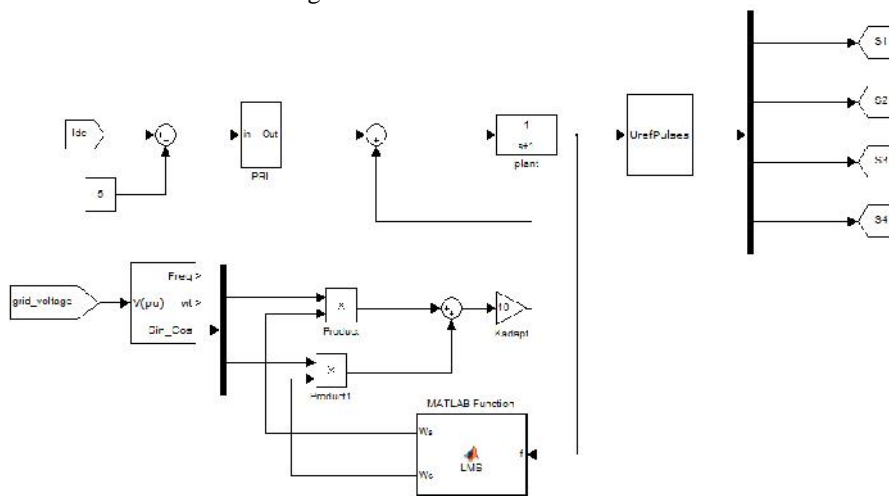

Figure 5: Block diagram of PRI controller

From the Fig.5 PRI controller means Proportional Resonant Integral controller. In this controller the values of $K_p=3$, $K_r=594$, $K_i = 100$.

Simulink results of Grid connected single-phase PV inverter with PRI controller

The Output waveforms of Grid connected single-phase PV inverter with PRI controller is shown in fig.6.

From the output waveforms Shown in Fig.6. It is observed that the grid current, grid voltage & primary current are in sinusoidal form. Total harmonic distortion in Primary current of single-phase PV inverter with PRI controller. It is observed that the THD in Grid current is 1.85%.

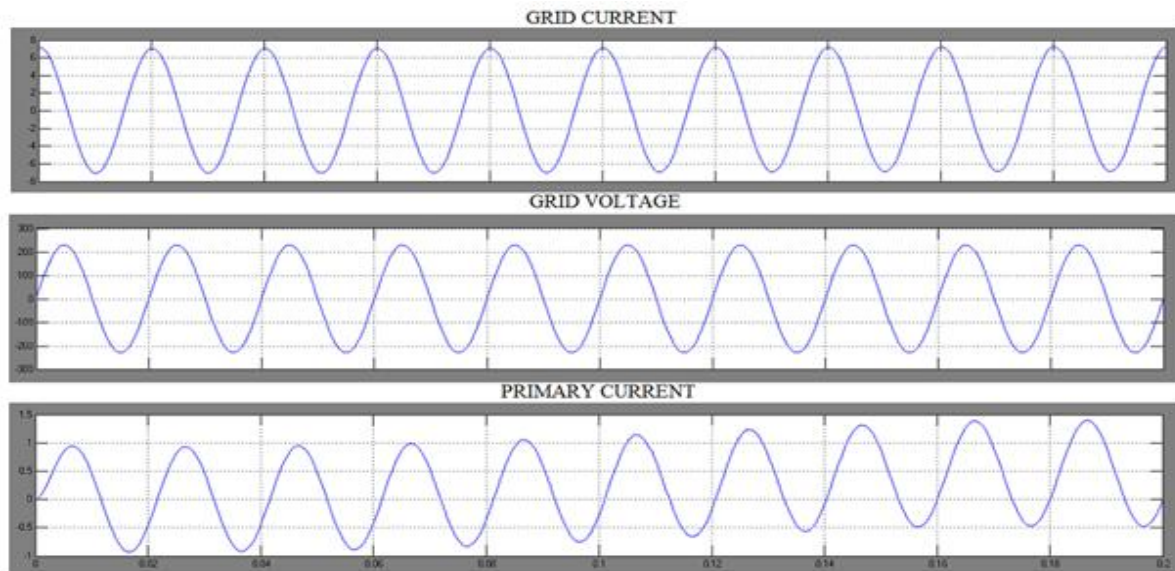

Figure 6: Output waveforms of Grid connected single-phase PV inverter with PRI controller.

Table 1: THD Analysis

	Total Harmonic Distortion (THD) (%)		
	Grid current	Grid voltage	Primary current
Before compensation	9.13	0	9.14
PR controller	0.16	0	2.91
PRI controller	0.03	0	1.85

The proposed single-phase PV inverter is simulated using MATLAB/SIMULINK. The corresponding results are showed before compensation, during PR& PRI controllers. Then the THD analyses for the proposed single-phase PV inverter with compensation and without compensation are compared.

4. Conclusion

Modification to the inverter current control for a grid connected single-phase photovoltaic inverter has been proposed in this paper, for ensuring high quality of the current injected into the grid. For the power circuit topology considered, the dominant causes for lower order harmonic injection are identified as the distorted transformer magnetizing current and the dead time of the inverter. It is also shown that the presence of dc offset in control loop results in even harmonics in the injected current for this topology due to the dc biasing of the transformer. A novel solution is proposed to attenuate all the dominant lower order harmonics in the system. The proposed method uses an LMS adaptive filter to estimate a particular harmonic in the grid current that needs to be attenuated. The estimated current is converted into an equivalent voltage reference using a proportional controller and added to the inverter voltage reference. The design of the gain of a proportional controller to have an adequate harmonic compensation has been explained. To avoid dc biasing of the transformer, a novel PRI controller has been proposed and its design has been presented. The interaction between the PRI controller and the adaptive compensation scheme has been

studied. It is shown that there is minimal interaction between the fundamental current controller and the methods responsible for dc offset compensation and adaptive harmonic compensation. The PRI controller and the adaptive compensation scheme together improve the quality of the current injected into the grid.

References

- [1] R. C´ardenas, C. Juri, R. Pen˜na, P. Wheeler, and J. Clare, "The application of resonant controllers to four-leg matrix converters feeding unbalanced or nonlinear loads," *IEEE Trans. Power Electron.*, vol. 27, no. 3, pp. 1120–1128, Mar. 2012.
- [2] S. Jiang, D. Cao, Y. Li, J. Liu, and F. Z. Peng, "Low-THD, fast-transient, and cost-effective synchronous-frame repetitive controller for three-phase UPS inverters," *IEEE Trans. Power Electron.*, vol. 27, no. 6, pp. 2994–3005, Jun. 2012.
- [3] J. M. Olm, G. A. Ramos, and R. Costa-Costel´o, "Stability analysis of digital repetitive control systems under time-varying sampling period," *IET Control Theor. Appl.*, vol. 5, no. 1, pp. 29–37, Jan. 2011.
- [4] Q. Mei, M. Shan, L. Liu, and J. M. Guerrero, "A novel improved variable step-size incremental-resistance MPPT method for PV systems," *IEEE Trans. Ind. Electron.*, vol. 58, no. 6, pp. 2427–2434, Jun. 2011.
- [5] A. K. Abdelsalam, A. M. Massoud, S. Ahmed, and P. N. Enjeti, "High-performance adaptive perturb and observe MPPT technique for photovoltaic-based microgrids," *IEEE Trans. Power Electron.*, vol. 26, no. 4, pp. 1010–1021, Apr. 2011.
- [6] R. Kadri, J.-P. Gaubert, and G. Champenois, "An improved maximum power point tracking for photovoltaic grid-connected inverter based on voltage-oriented control," *IEEE Trans. Ind. Electron.*, vol. 58, no. 1, pp. 66–75, Jan. 2011.

- [7] A. G. Yepes, F. D. Freijedo, O' . Lo'pez, and J. Doval-Gandoy, "High performance digital resonant controllers implemented with two integrators," *IEEE Trans. Power Electron.*, vol. 26, no. 2, pp. 563–576, Feb.2011.

Author Profile

SK.SHAKEER AHAMMAD, received B.Tech, and M.Tech degrees in Electrical Engineering from Jawaharlal Nehru Technological University, India. Currently he is working as Asst. Professor in Electrical and Electronics Engineering at, AMC Engineering College, Bangalore.

T.MUNI PRAKASH, received B.Tech, and M.Tech degrees in Electrical Engineering from Jawaharlal Nehru Technological University, India. Currently he is working as Asst. Professor in Electrical and Electronics Engineering at, Sir Vishveshwaraiah Institute Of Science & Technology, Madanapalli.

P.MURALI received B.Tech, and M.Tech degrees in Electrical Engineering from Jawaharlal Nehru Technological University, India. Currently he is working as Asst. Professor in Electrical and Electronics Engineering, at Narayana Engineering College, India. His research interests include Power Quality, and Power Systems. He is life member of ISTE.